

SITE 5 Repair and Replacement

<i>Repairing Therma-Tru Door Slabs</i> -----	5.3
<i>Sidelite Slab Replacement</i> -----	5.6
<i>Mull Post Replacement</i> -----	5.12
<i>Weatherstrip Replacement</i> -----	5.20
<i>Adjustable Sill Oak Threshold Replacement</i> -----	5.21
<i>Self-adjusting Sill vinyl Threshold Replacement</i> ---	5.24
<i>Doorlite Door Strip Application (Continuous Sill)</i> ---	5.29

Stile Chips

Fill Chips and Sand Smooth

Fill minor cosmetic damage to wood stiles with a hardening type wood putty.

File and sand smooth.

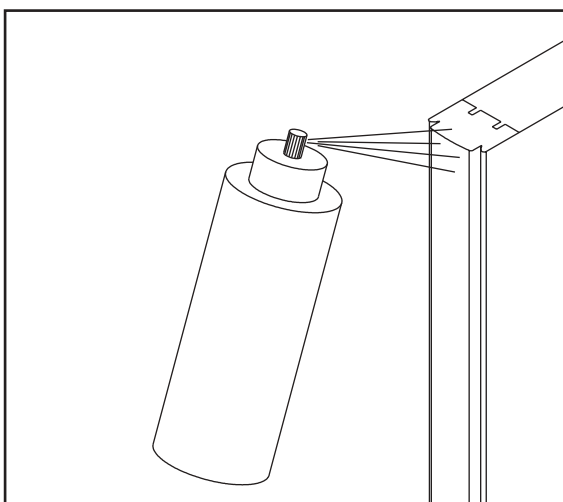
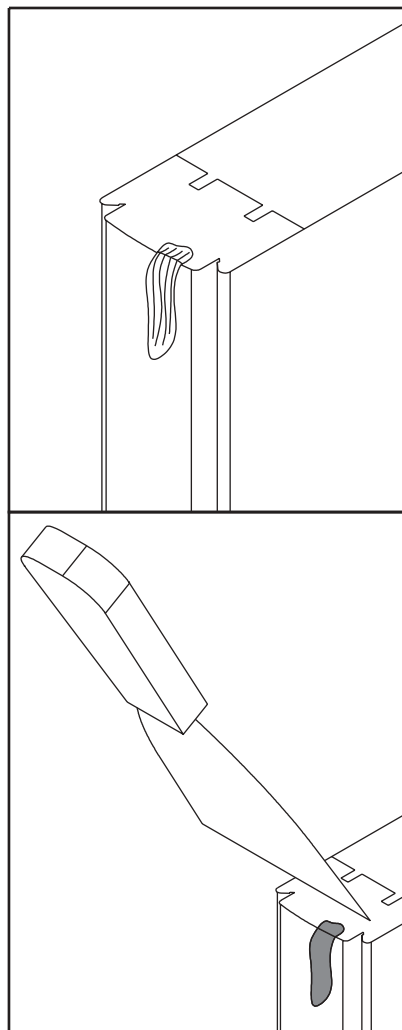

Reprime Area Using Touch-up Paint

**Repair
and
Replacement**

Repairing Therma-Tru Door Slabs

Steel Door Dent Repair

Clean and Roughen Surface

Clean surface surrounding dent.

Roughen using 100 grit sandpaper.

If possible, do not sand through the existing factory-applied primer.

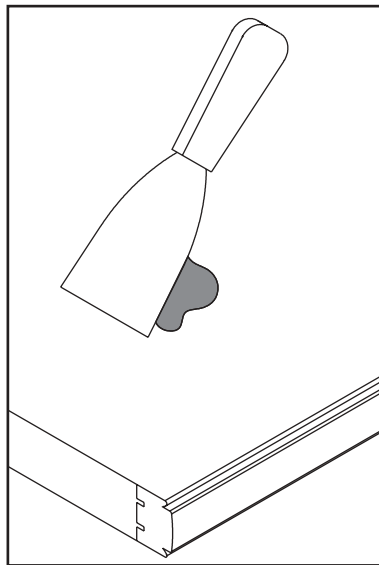
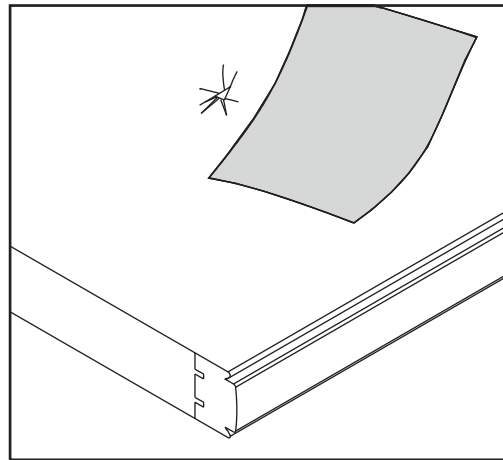

Fill Dent

Fill dent using Therma-Tru Dent Repair Kit (Part # MS00DRK) or an automotive body-filler compound.

Smooth using a wide-blade putty knife.

Overfill to account for shrinkage and sanding.

Sand Dent Repair

Sand repair using a large sanding block or orbital power sander with 220 grit sandpaper.

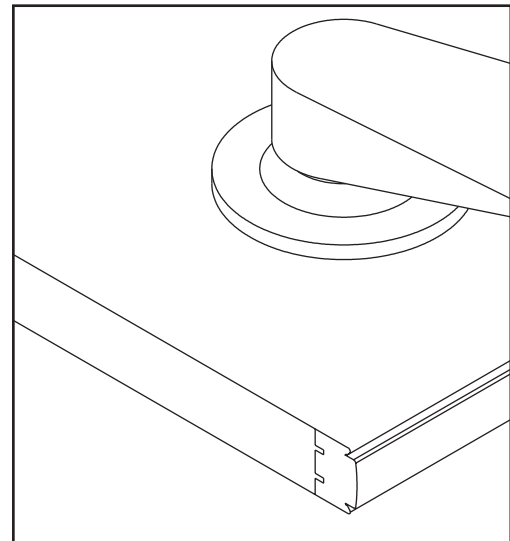

Re-prime Repair Area(s)

If bare metal was exposed, paint entire repair area with a primer containing rust inhibitors.

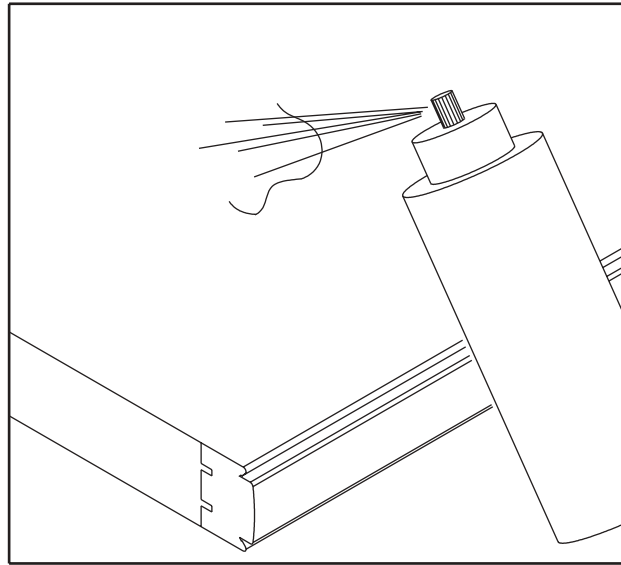

THERMA-TRU TOUCH-UP PRIMERS

Description	Part No.
Premium Steel White Primer	MSWHABP-01
Construction Series Gray Primer	MS00ABP-01
Classic-Craft Oak or Rustic, and Fiber-Classic Primer	MSCCAB-01
Classic-Craft Mahogany Primer	MSCCMAB
Smooth-Star Primer	MSWHSABP-03

Re-prime repaired area using Therma-Tru touch-up primer. If a rust inhibiting primer was used, let dry thoroughly before applying Therma-Tru touch-up primer.

Classic-Craft and Fiber-Classic Skin Repair

For minor scratches in Classic-Craft Rustic & Oak, or Fiber-Classic doors, use Classic-Craft & Fiber-Classic Primer (Part # MSCCAB-01) to touch up.

For minor scratches in Classic-Craft Mahogany doors, use Primer (Part # MSCCMAB) to touch up.

For minor scratches in Smooth-Star doors, use Smooth-Star White Primer (Part # MSWHSABP-03) to touch up.

For deep scratches, fill with crayon or patch pencil.

Therma-Tru does not recommend any other repair procedures for composite doors.

Sidelite Slab Replacement

Remove Cove Molding and Inside Vertical Casing if applicable

Remove and set aside cove molding.

If post between sidelite and door is two "mulled" jambs, remove casing there also.

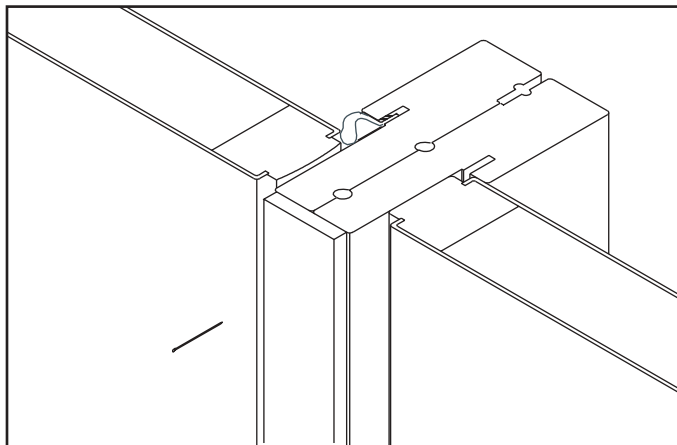
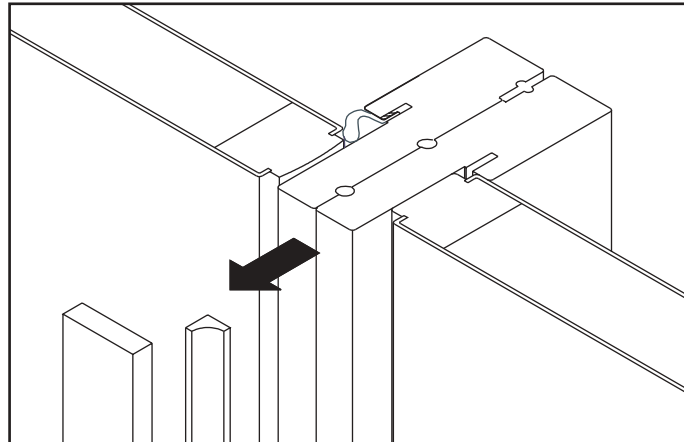

Tack on Protective Strips

Tack on softwood strips to protect jamb and mullion faces adjacent to sidelite slab.

Locate Fasteners

Find fasteners by running a putty knife blade in the margins and marking the locations.

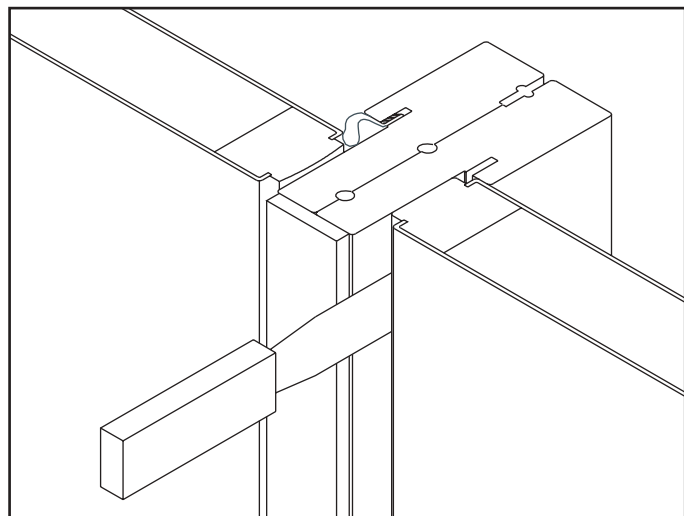

Cut Through Fasteners

Use a reciprocating saw with a metal cutting blade to cut through fasteners.

Run sawblade in margin.

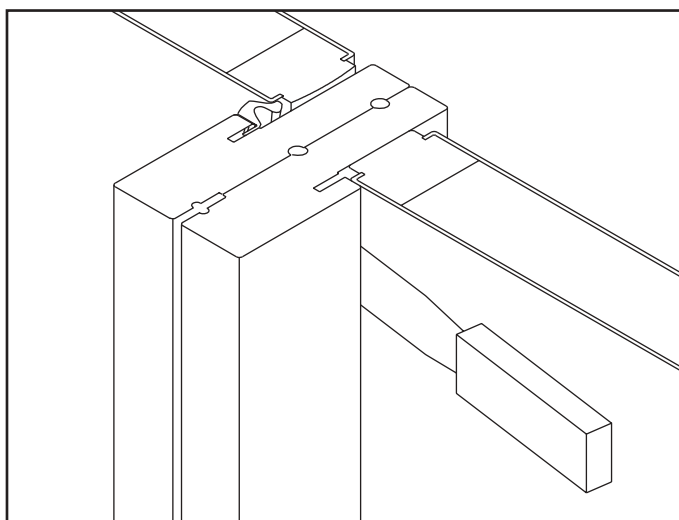
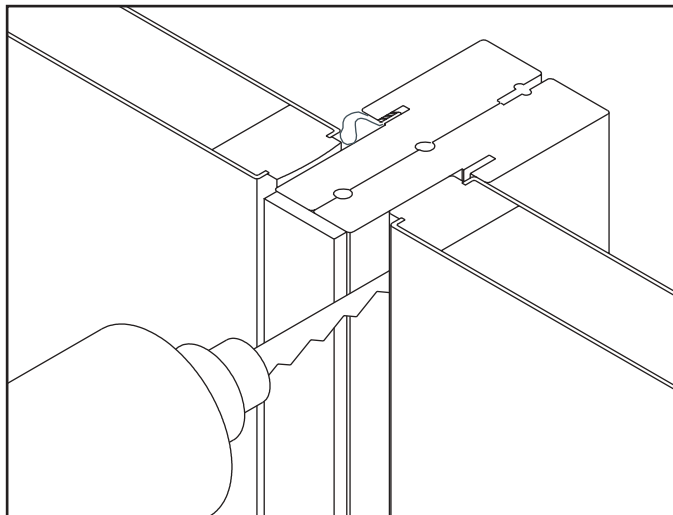

Cut Sealant Joints

On outside face of unit, use putty knife and cut through sealant joints along head and at sides.

**Repair
and
Replacement**

Remove Slab

Push slab through from outside.

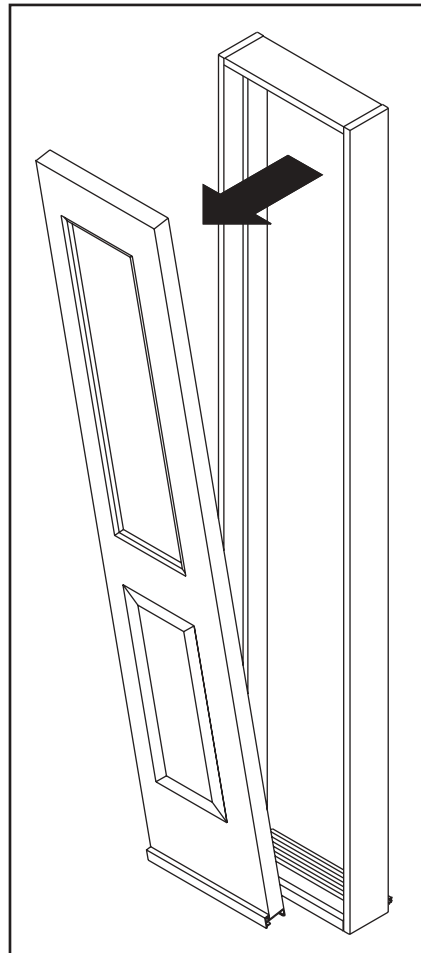

Repair
and
Replacement

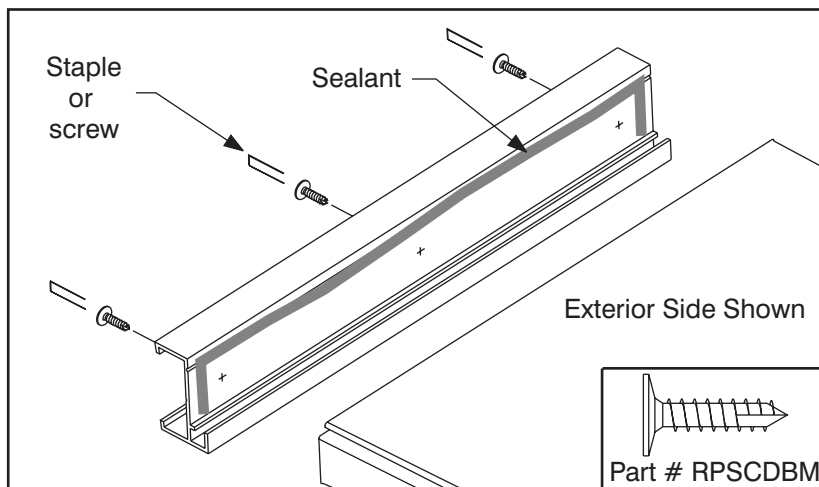

Prep New Sidelite Slab

Install desired lites and/or panels into sidelite slab.

Apply a 1/4" bead of sealant to door bottom and fasten with 1" staples or #8-15 x 3/4" Phillips dual angle wafer head type 17 gimlet point screws.

Prepare Opening for New Slab

Cut away and clean off all old caulking.

Cut away all old fasteners flush with frame using side-cutting pliers for staples or a saw for screws.

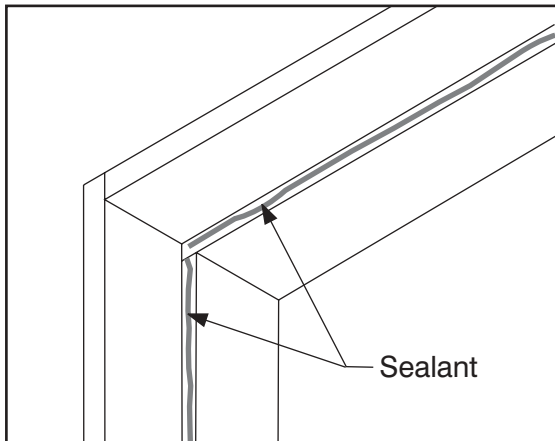
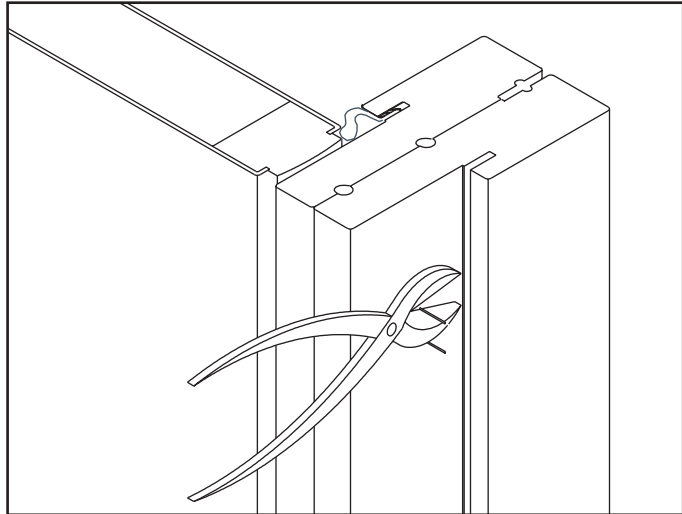

Caulk Jamb and Header Stops

Apply a 1/4" bead of sealant on side and head jambs to ensure weather seal.

Caulk Sill Where Door Bottom Meets

Apply a 1/4" bead of sealant along length of sill where sidelite door bottom makes contact.

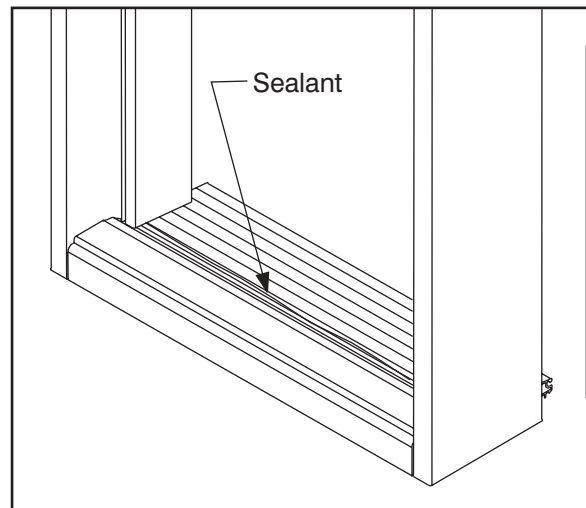

**Repair
and
Replacement**

Sidelite Slab Replacement

Install New Sidelite Slab

Place sill end first, mating plastic bottom to sill.

If necessary, use putty knife blade at top to aid insertion of slab in frame.

Slabs are nominally 1/16" narrower than frame opening, for 1/32" clearance on each side.

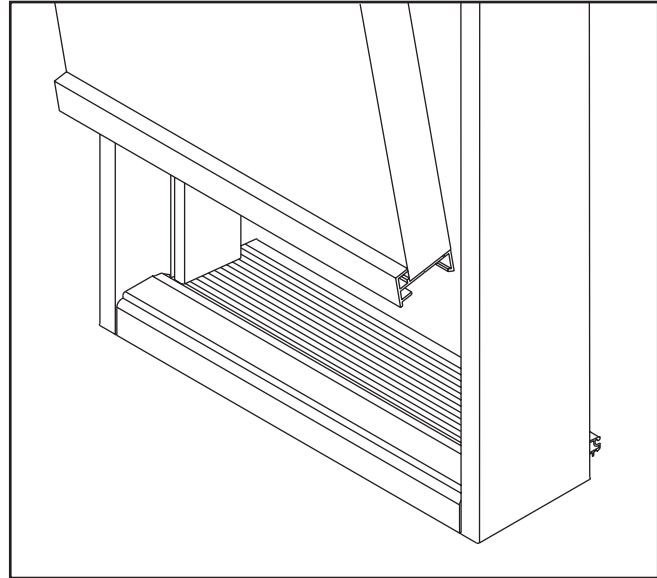

Fasten New Sidelite Slab

Space four fasteners along both sides.

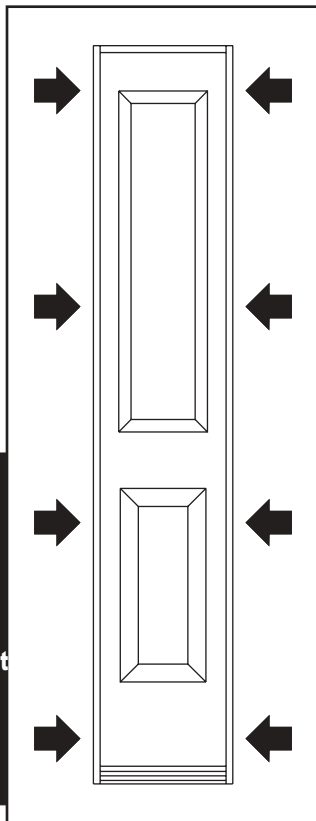

"Mulled" Jamb Application

Drill angled pilot holes through frame.

Use 2" drywall screws and fasten frame to slab at pilot holes.

Sink screw head in so as not to interfere with mullion casing (applied later).

Mullion Application

Fasten through mullion using 2" finishing nails.

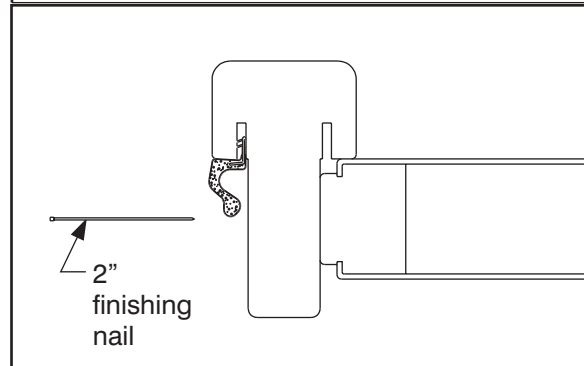
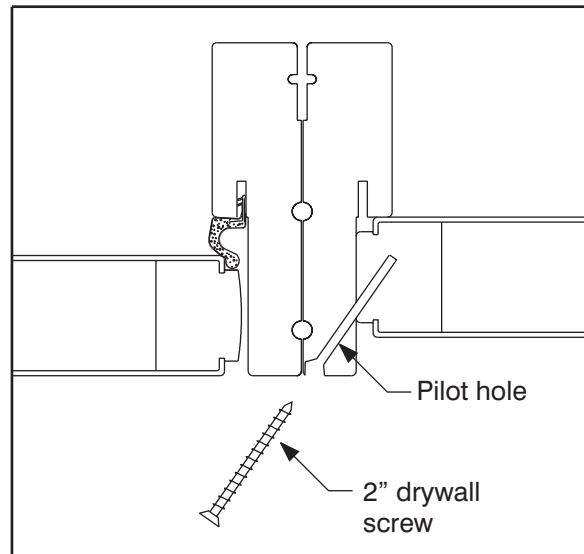

Repair
and
Replacement

***Re-apply Cove Molding and
Inside Vertical Casing if applicable***

Re-apply cove molding and casing to the new sidelite slab unit.

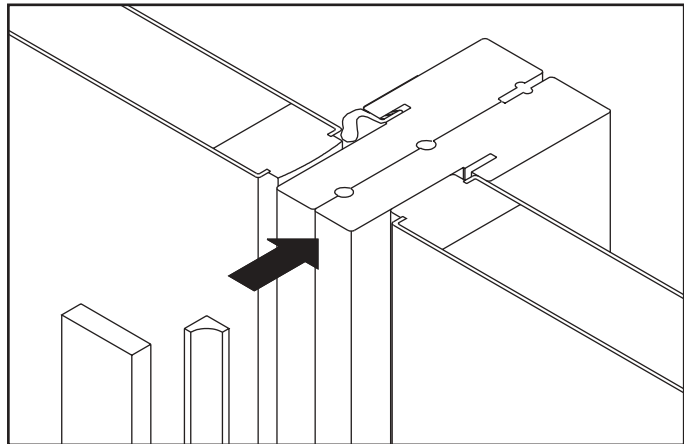

**Repair
and
Replacement**

Mull Post Replacement

Remove Active Door

Unlatch door and remove hinge pins.

Carefully remove door and set aside.

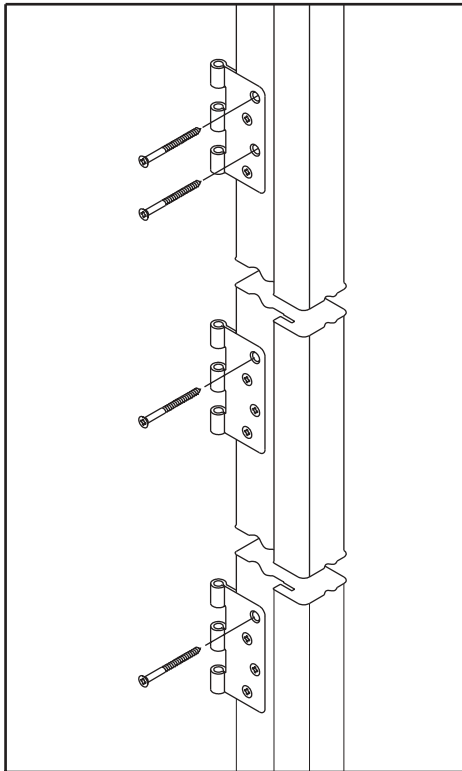
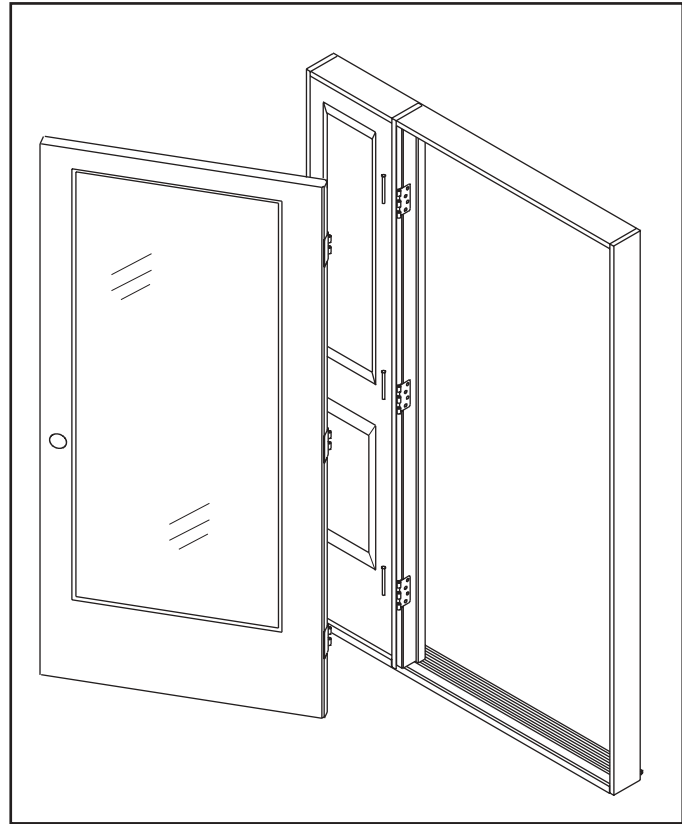

Remove Long Hinge Screws

NOTE: Inactive slab is fastened to mullion with four long (2-1/2") hinge screws.

Locate and remove long screws. Set aside.

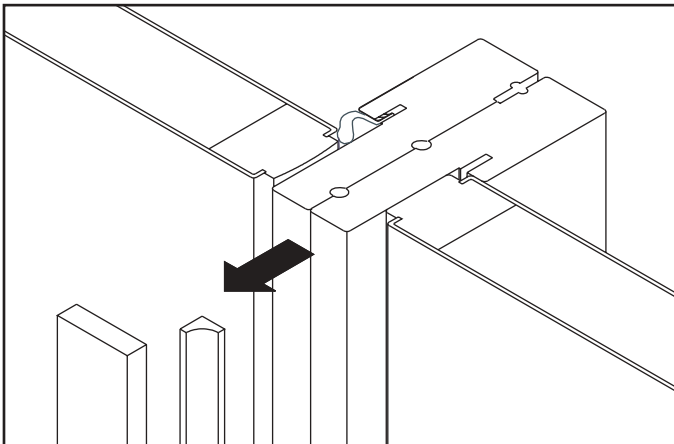

Remove Cove Molding and Inside Vertical Casing if applicable

Remove and set aside cove molding from inactive panel and set aside.

If post is two "mulled" jambs, remove vertical casing.

Repair
and
Replacement

Remove Any Additional Mullion Side Fastening

Examine mullion carefully to ensure no other staples or screws were used to fasten slab.

Run a putty knife blade down margin between slab and mullion to double-check.

If any fasteners are found, using a reciprocating saw with a metal-cutting blade, slice through fasteners. Run sawblade in margin.

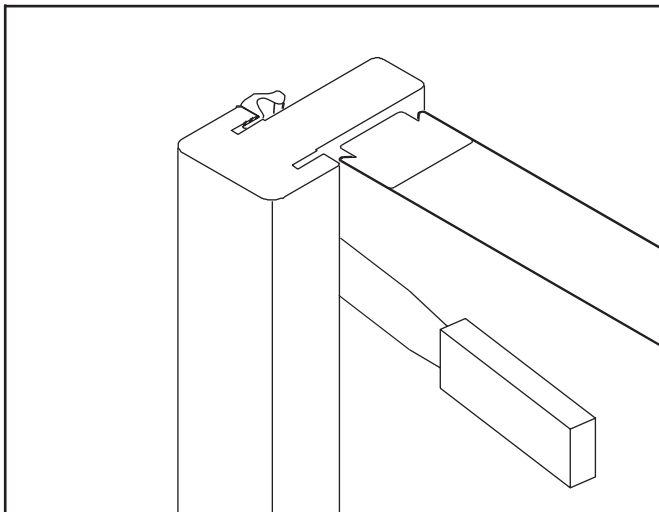
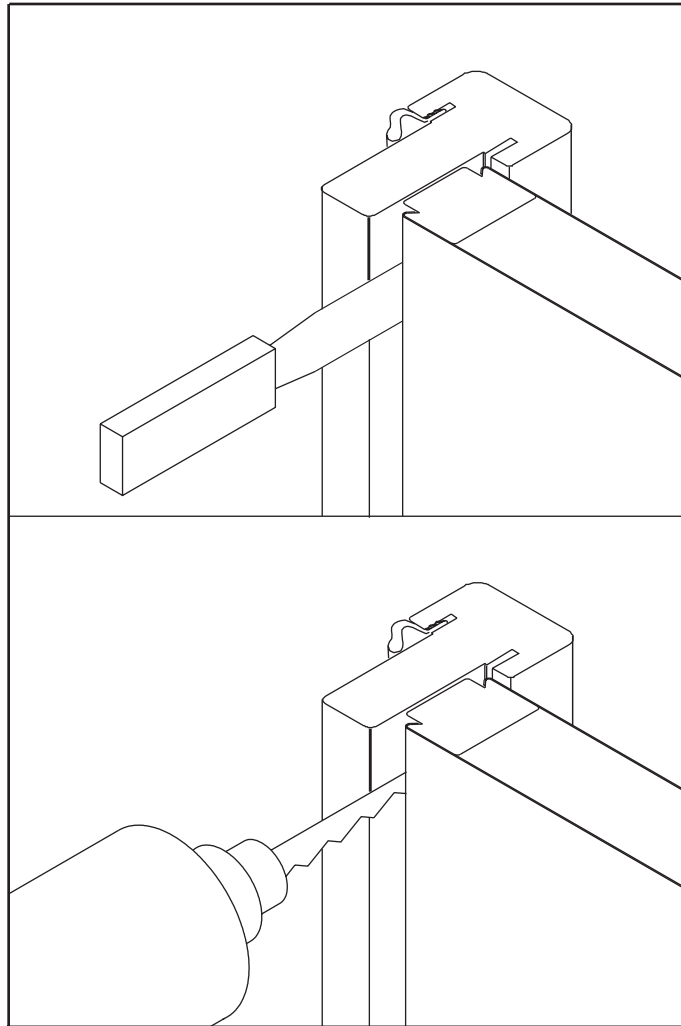

Cut Sealant Joints

On outside face of unit, use a putty knife and cut through sealant joints along head and at sides.

**Repair
and
Replacement**

Mull Post Replacement

Remove Inactive Sidelite Slab

Push inactive slab in from the outside at mullion side. Door will pivot on staples on jamb side. Support slab while pivoting. Open slab far enough to cut staples attaching slab to jamb. Remove slab.

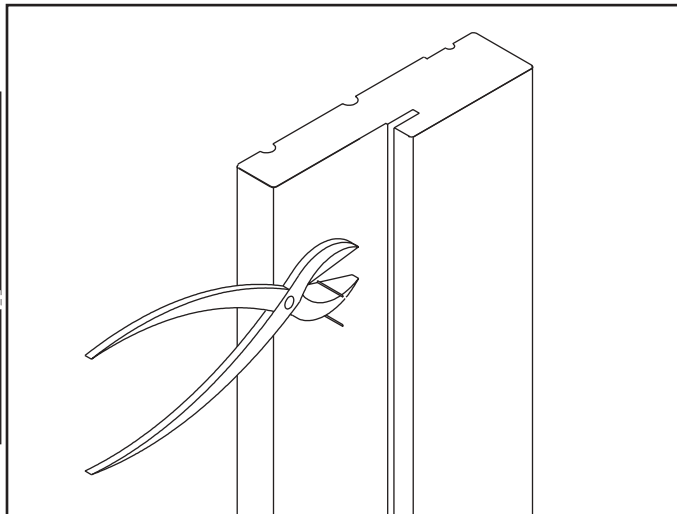
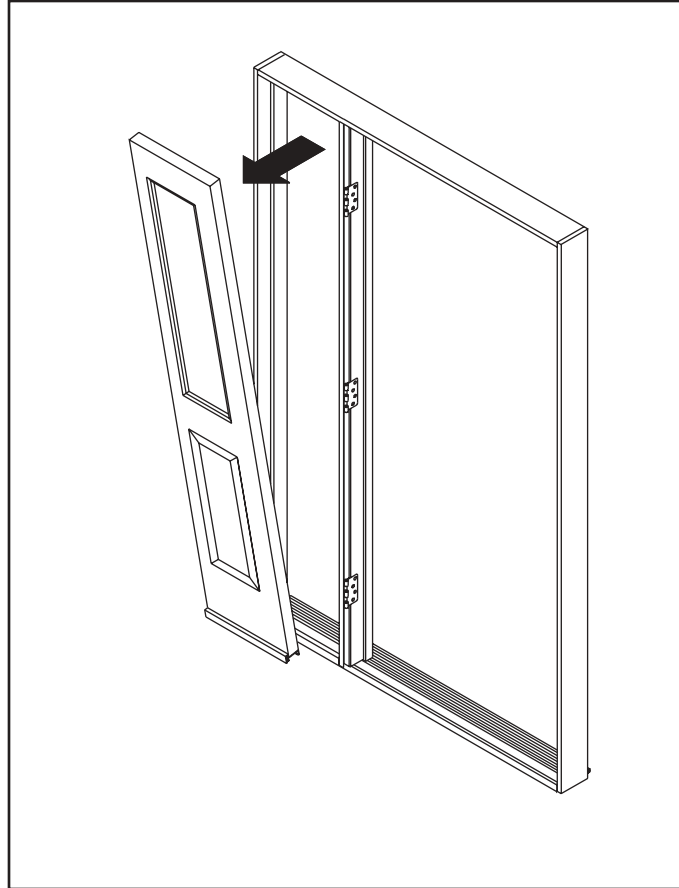

Prepare Opening

Cut away and clean off old caulking.

Cut away all staples flush with jamb using side-cutting pliers

Repair
and
Replacement



CAUTION:
Adjustable Sill Systems:

Remove adjustable oak saddle and corner seal pad from sill.

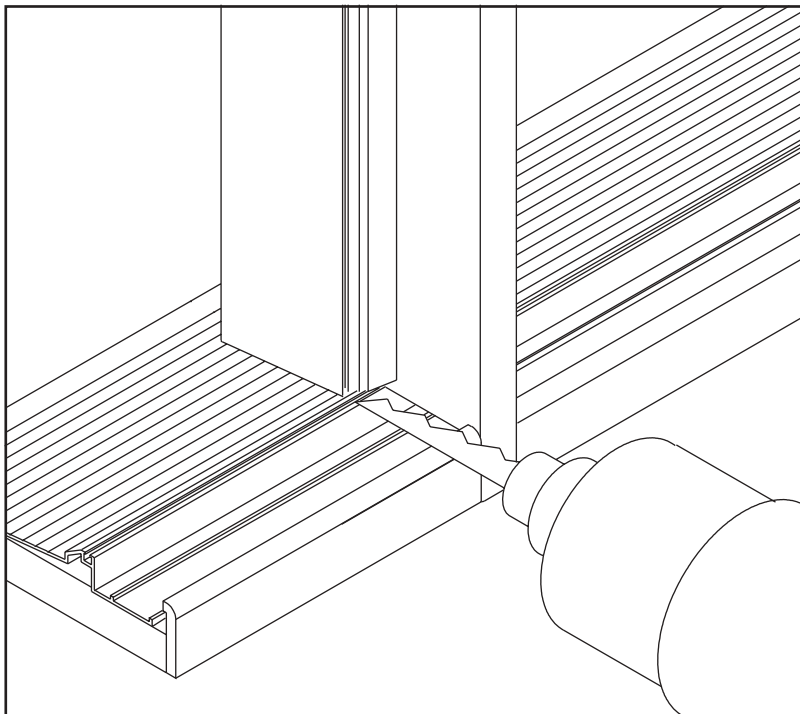
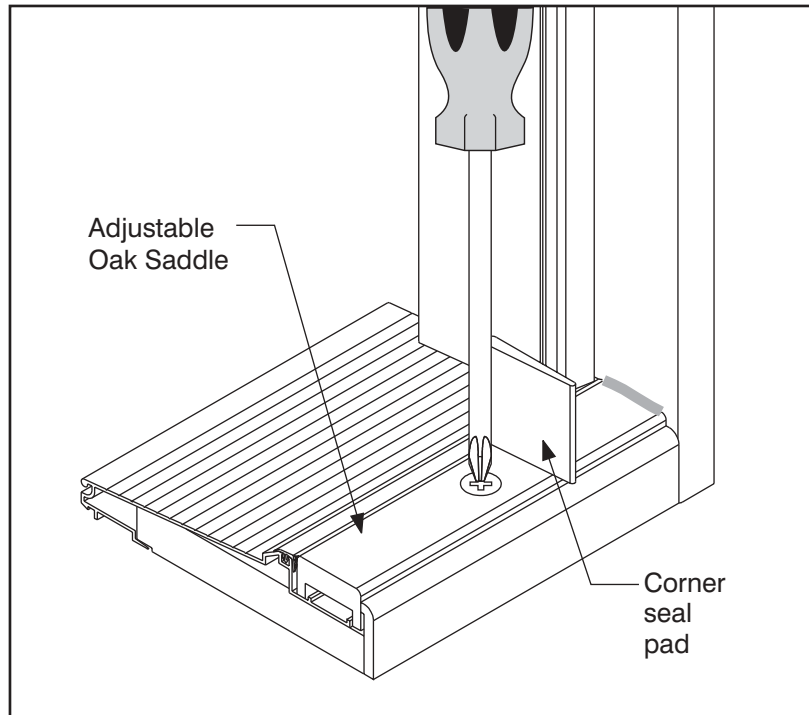

Cut mull post loose as close to head and sill as possible.

Use a chisel to split ends of mull post clean from head and sill mortise pockets.

Cut away all old fasteners flush with head frame and sill substrate. Cut away and clean off all old caulk.

**Repair
and
Replacement**

Mull Post Replacement

Install New Mull Post

Apply sealant to bottom end of mull post and insert into sill detail.

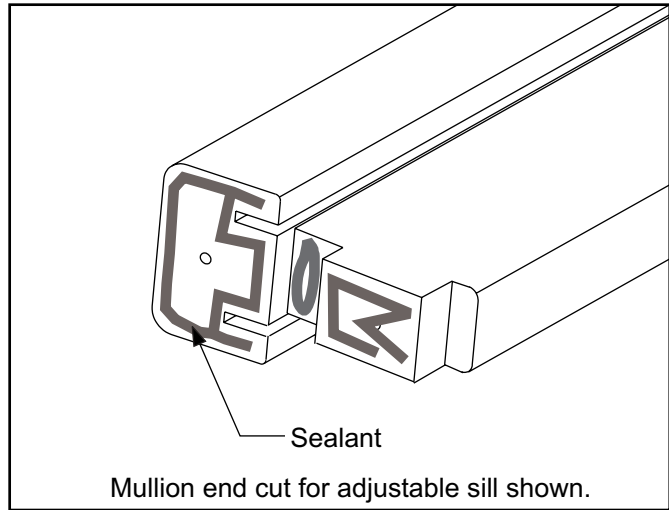
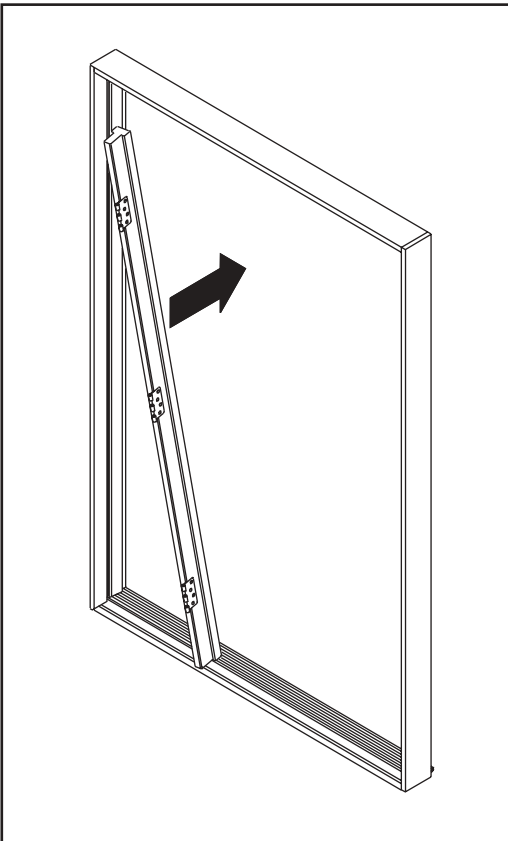

Slide head end of mull post into head mortise pocket.

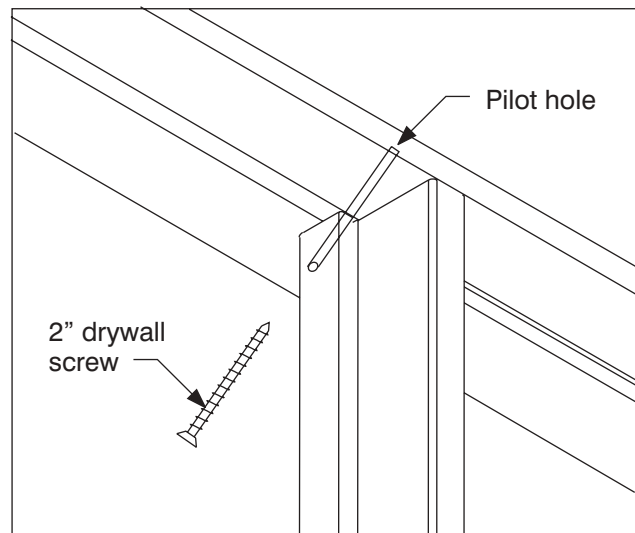

Pre-drill holes on an angle through mull post and then secure with screws into sill and head frame.

Repair
and
Replacement

Reinstall Inactive Sidelite Slab



CAUTION:
Be sure all caulk and any old fasteners have been removed from entire frame and sill



CAUTION:
Do not use door bottoms for outswing doors.

Caulk and Fasten Inactive Door Bottom

Select a sealant that provides excellent adhesion to both plastic and wood.

Apply a very large bead of sealant along length ends of door bottom.

Align at ends and against inside face with lip

Fasten in place with 1/4" crown x 3/4" or 7/8" Staples or #8-15 x 3/4" phillips head screws, beginning at center.

Work toward each end and fasten on 3" centers.

Clean-up any sealant squeeze-out.

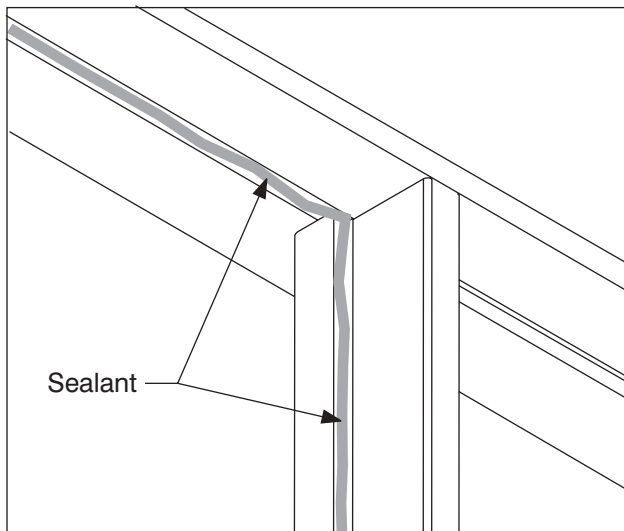
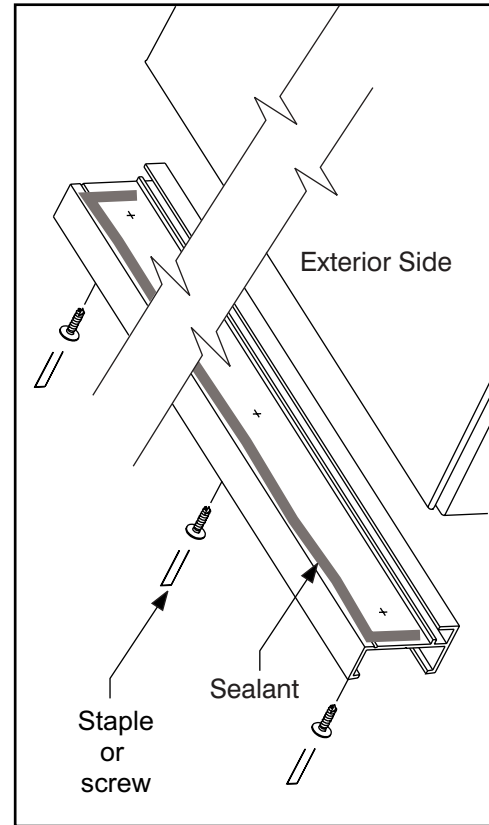

Caulk Jamb, Header and Mullion



CAUTION:
Do not caulk for outswing doors. Slabs install against weatherstrip and sill bumper.

Apply a 1/4" bead of sealant to rebate on inactive side of jambs, header and mullion to ensure a weather seal.

**Repair
and
Replacement**

Mull Post Replacement

Caulk Sill (Inswing Units Only)

Place 2 very large beads of sealant along top of sill (inactive side only).

See diagrams below for bead locations per sill type.

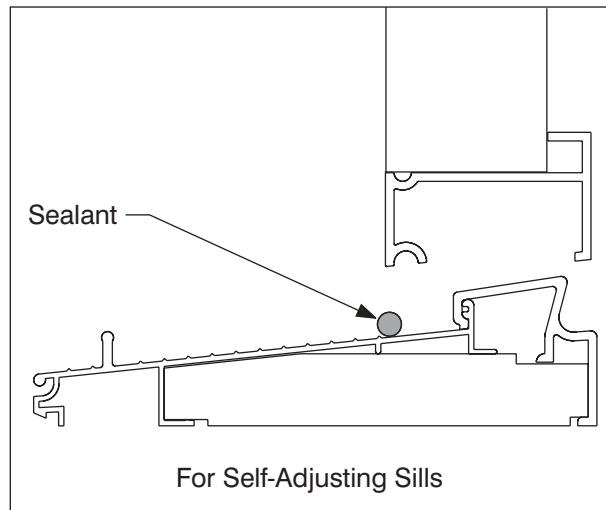
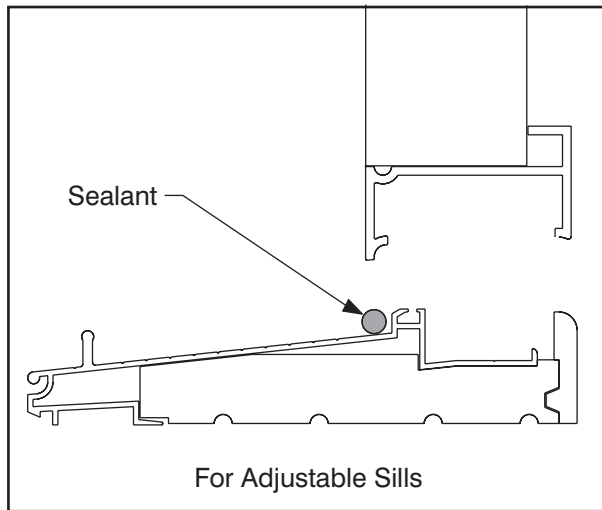
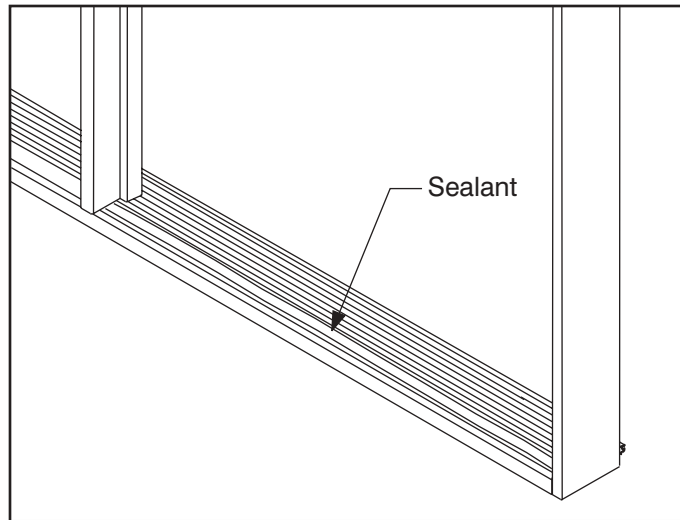

**Repair
and
Replacement**

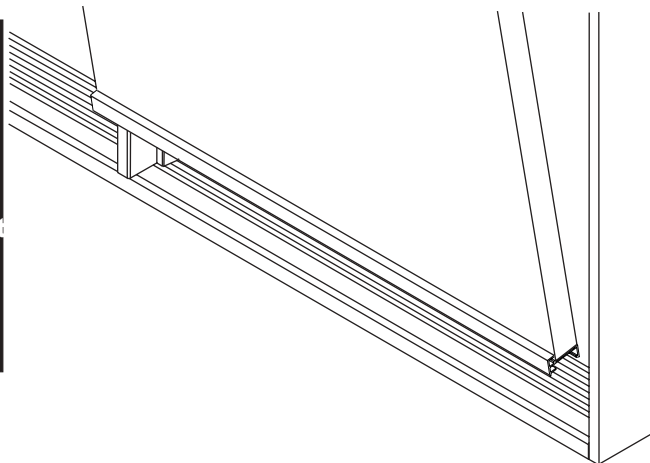

Reinstall Inactive Slab into Frame

Place sill end in first, mating door bottom to sill.

If necessary, use a putty knife blade at top to aid inserting slab into frame.

Align inside surface of door with inside edge of jamb. Door should be flush with jamb and head.

Check door bottom for proper seal.

Finish Up

Replace jamb casing.

Replace active slab.

Examine exterior joints between inactive slab, frame and sill.

Apply additional caulk at joints if required.

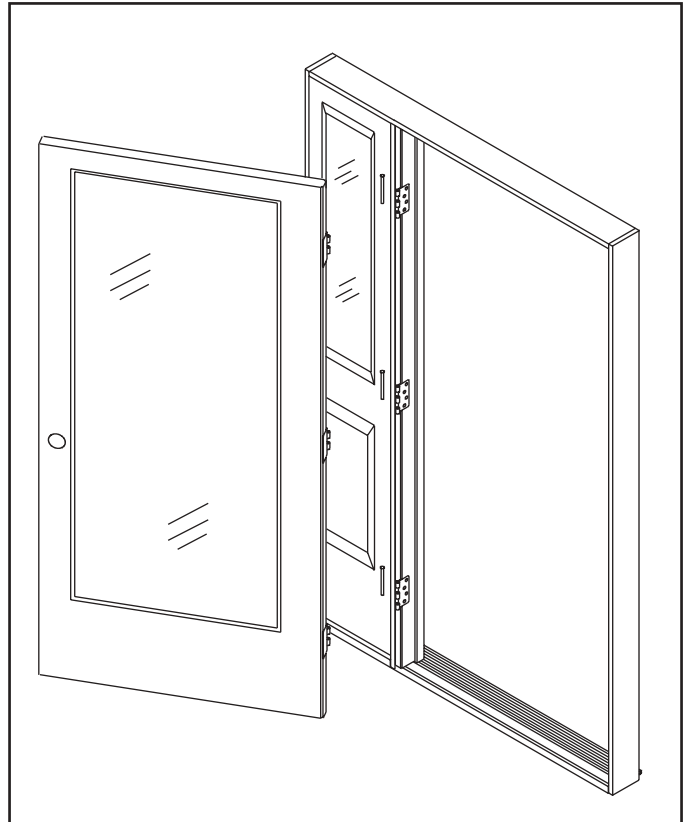

Re-apply Cove Molding and Inside Vertical Casing if applicable

Re-apply cove molding to the new sidelite Slab unit.

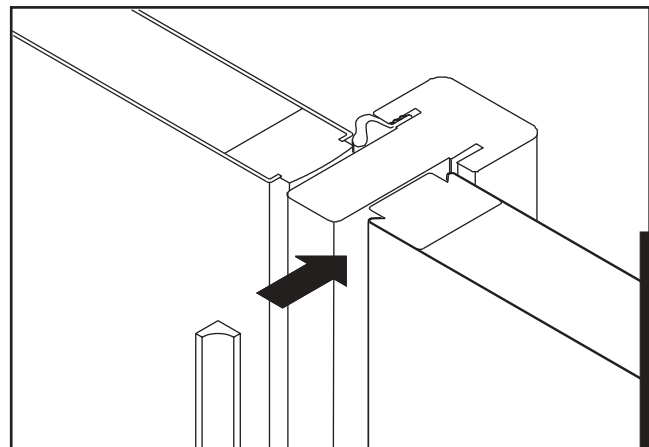

**Repair
and
Replacement**

Weatherstrip Replacement

Nail-In Weatherstrip

Use a sharp chisel or putty knife to break nails between weatherstrip and jamb.

Remove weatherstrip.

Apply compression weatherstrip to jamb.

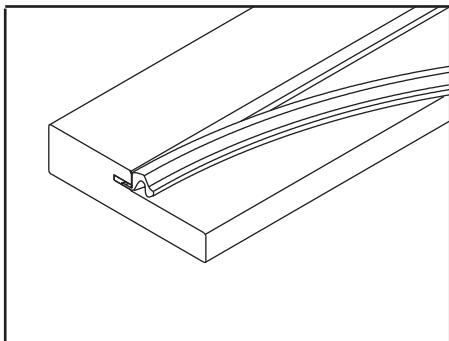
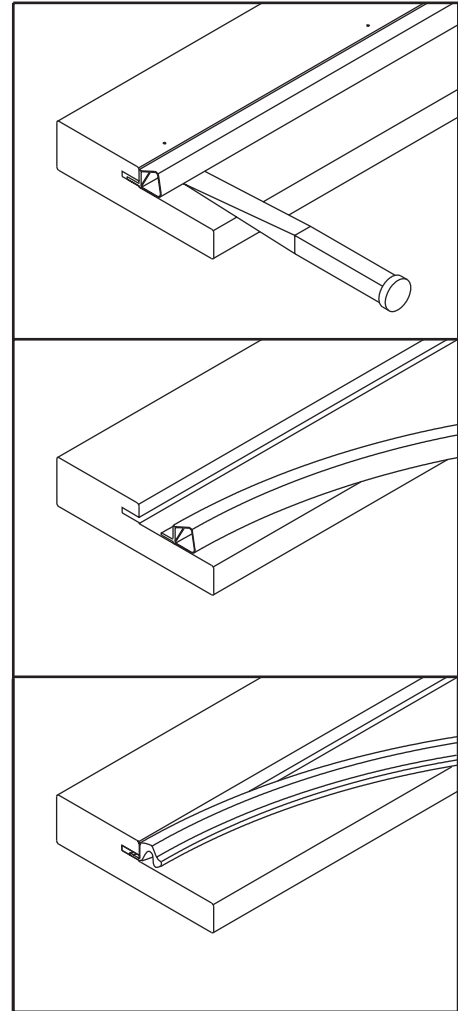

Press-In Weatherstrip

Remove existing weatherstrip from jambs.

Replace with new compression weatherstrip.

Repair
and
Replacement

Remove Corner Seal Pads

Break any sealant bonds.

Remove corner seal pads.

Clean off excess sealant.

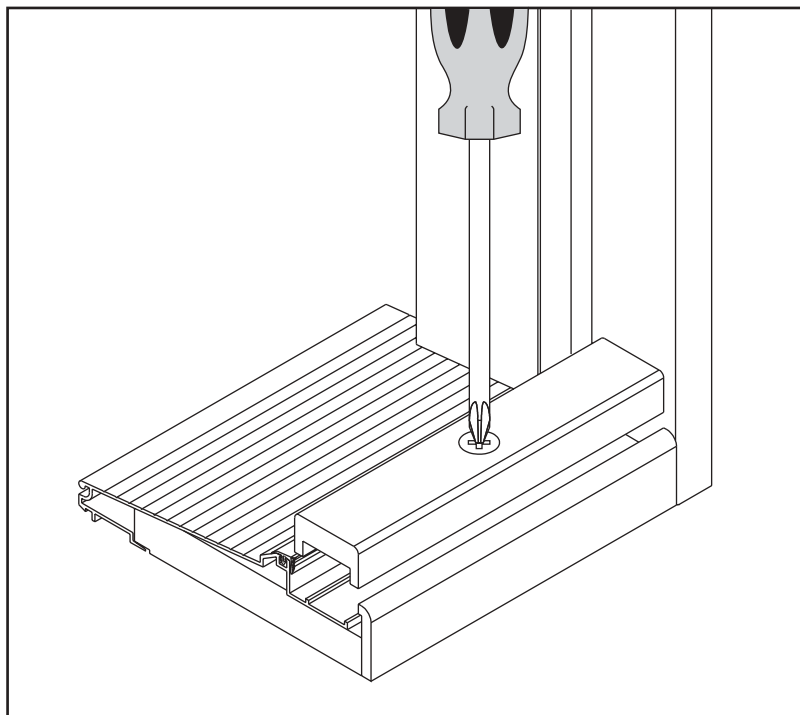
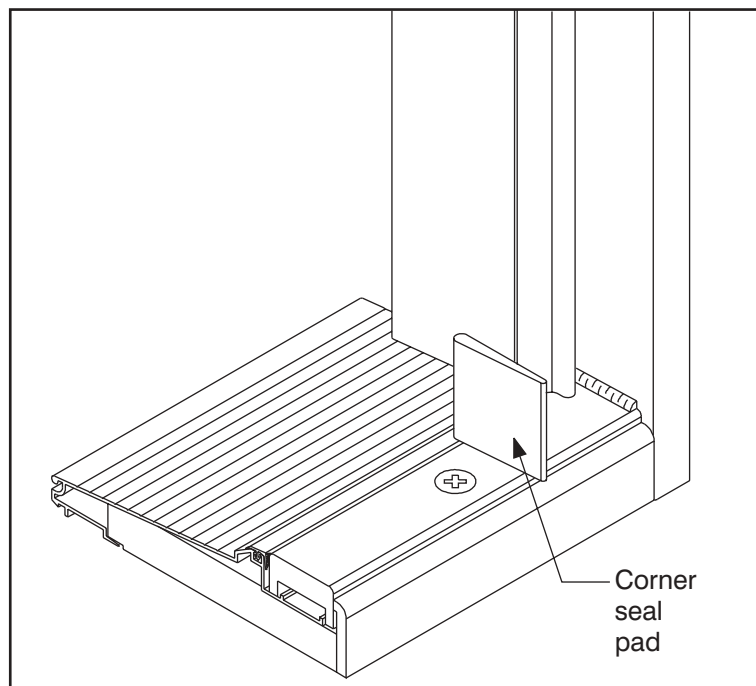

Remove Existing Threshold

Unscrew adjustment screws to remove threshold.

Carefully remove sill gasket from aluminum channel after oak threshold is removed.

**Repair
and
Replacement**

Adjustable Sill Oak Threshold Replacement

Determine Correct Replacement Part

- Measure distance between adjustment screws.
- Determine adjustment screw diameter.
- Determine sill saddle width.
- Determine sill type.
- Obtain correct replacement part.

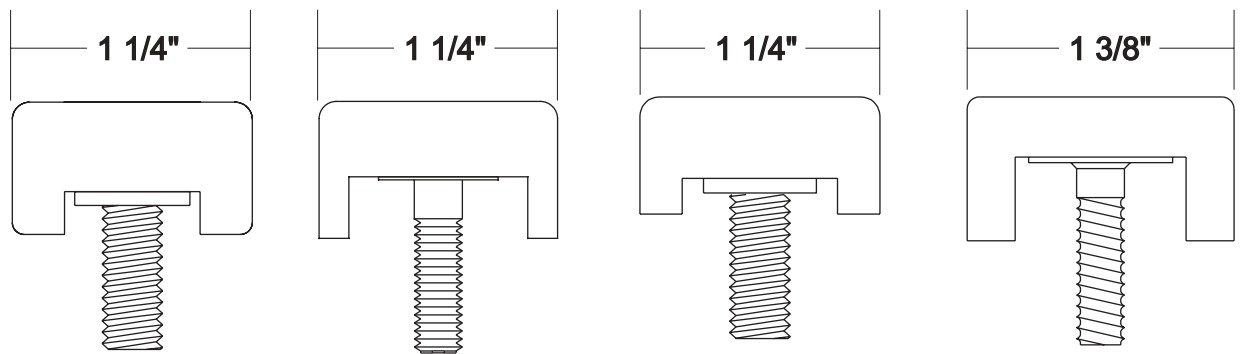
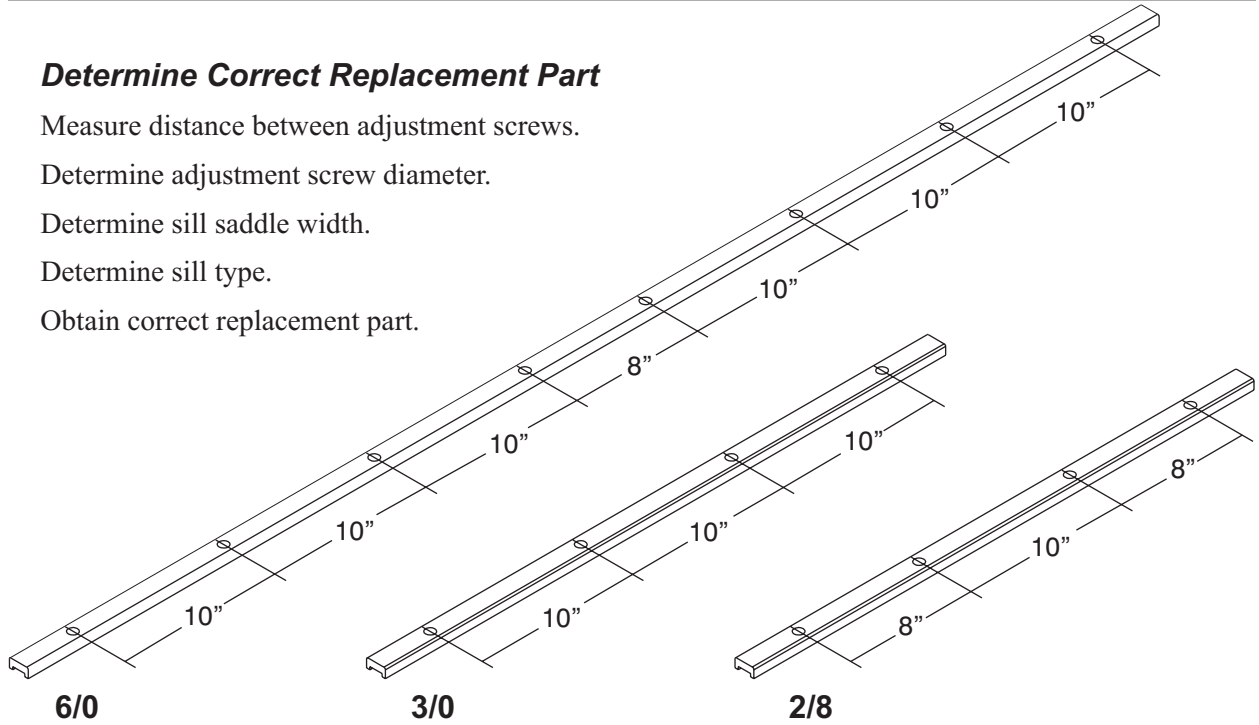

3/8" Dia. Screw	1/4" Dia. Screw	3/8" Dia. Screw	1/4" Dia. Screw
Monumental Oak Adjustable Sill	Premium Oak or Construction Series Adjustable Sill	Older Premium Oak Adjustable Sill	Older Construction Series Adjustable Sill

Sill Types	Screw Spacing	Screw Diameter/ Cap Width	Replacement Part Number
Monumental Oak Adjustable Sill	10-10-10 10-10-10-8-10-10-10	3/8" Dia. / 1-1/4"	RPAJMN3 RPAJMN6
Premium Oak or Construction Series Adjustable Sill	8-10-8 10-10-10 10-10-10-8-10-10-10	1/4" Dia. / 1-1/4"	RPAJOKRL2P RPAJOKRL3P RPAJOKRL6P
Older Premium Oak Adjustable Sill	8-10-8 10-10-10 10-10-10-8-10-10-10	3/8" Dia. / 1-3/8"	RPAJOLRL2 RPAJOLRL3 RPAJOLRL6
Older Construction Series Oak Adjustable Sill	8-10-8 10-10-10 10-10-10-8-10-10-10	1/4" Dia. / 1-1/4"	RPCAJOKRL2 RPCAJOKRL3 RPCAJOKRL6

Repair and Replacement

Fasten Threshold to Sill

NOTE: It may be necessary to trim new threshold so it fits properly. Trim both ends equally.

Insert threshold and screw down adjustment screws.

Insert sill gasket into aluminum channel after oak threshold has been installed.

Make any sill adjustments, if necessary, for a proper seal.

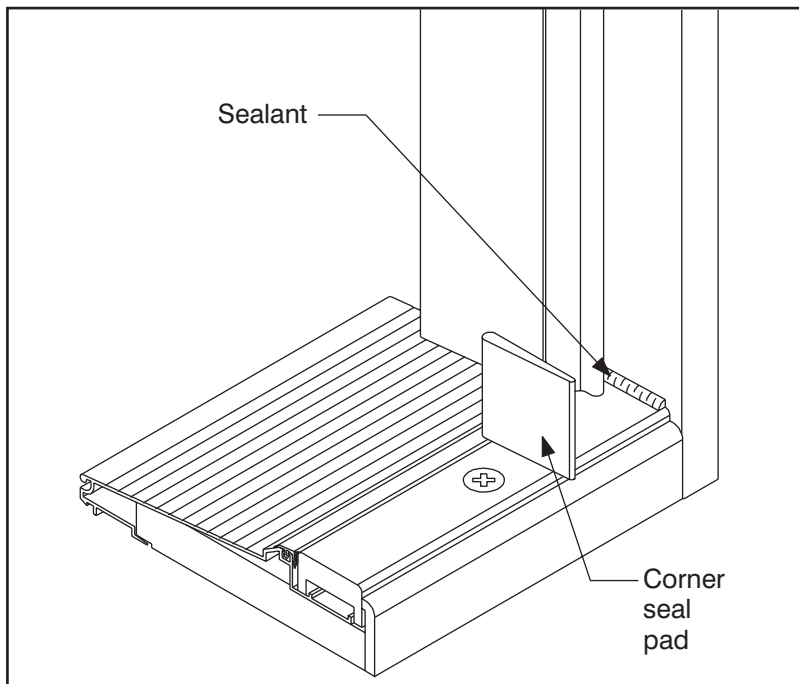
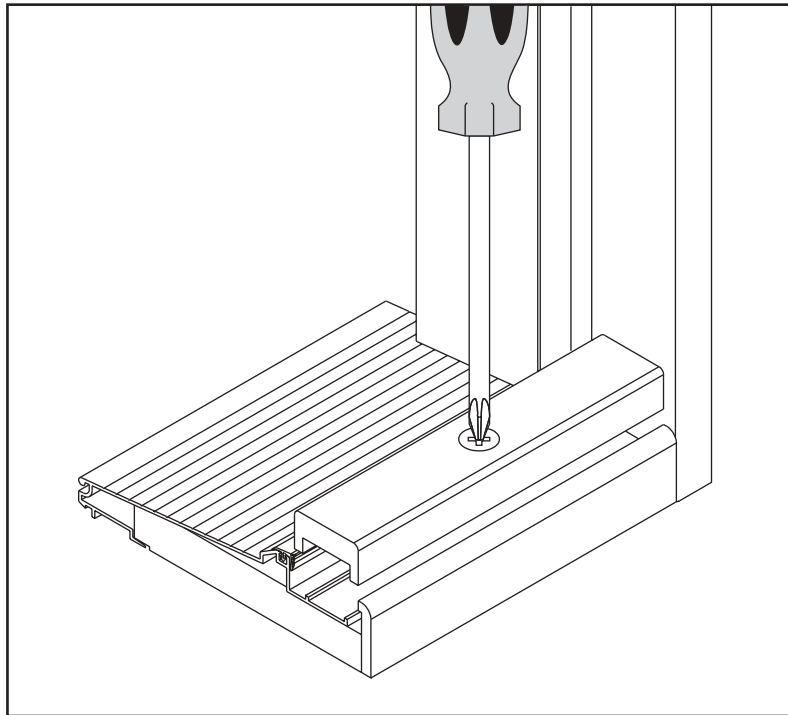

Apply Corner Seal Pads

After final threshold adjustments, apply a bead of sealant at sill/jamb joint.

Remove paper backing from pad and apply pad to jamb with bottom edge down against sealant, tucking behind weatherstrip.

**Repair
and
Replacement**

Self-Adjusting Sill Vinyl Threshold Replacement

Remove Corner Seal Pads

Break any sealant bonds.

Remove corner seal pads.

Clean off excess sealant.

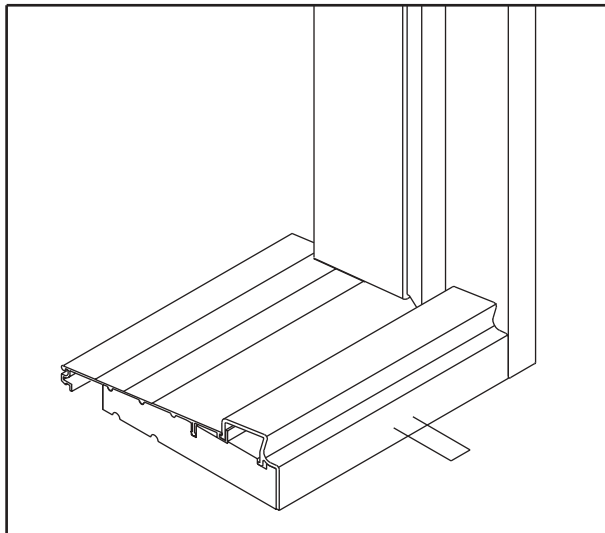
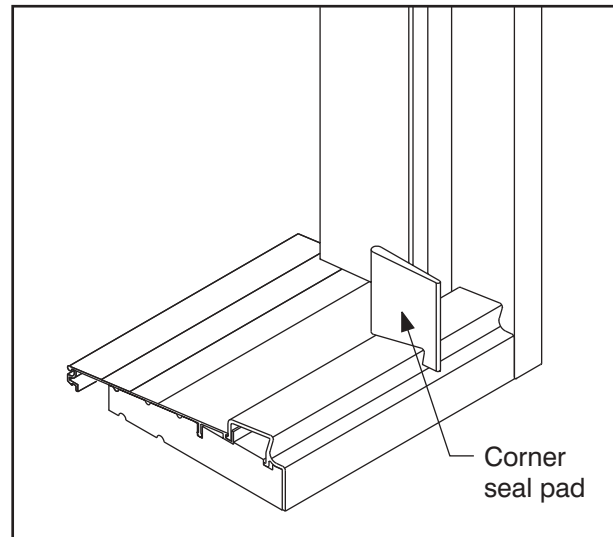

Remove Staples and/or Screws

Pull out staples that fasten vinyl threshold and any screws that may be fastened through the top of the threshold.

Pull off Vinyl Threshold

Carefully remove vinyl threshold so not to damage aluminum approach. It may be necessary to pry threshold off with a screw driver.

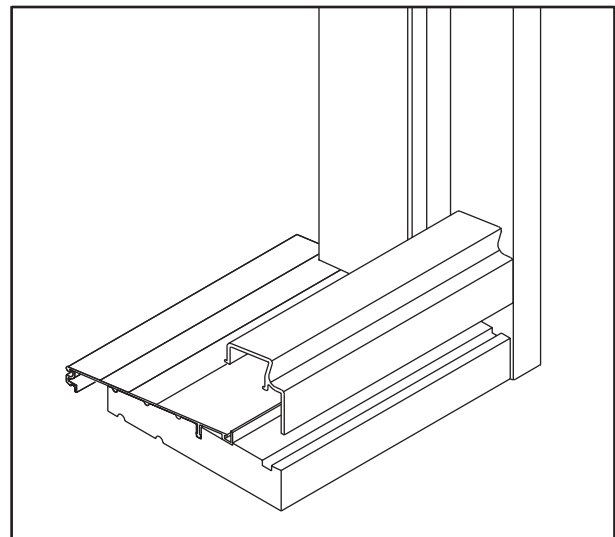

Determine Correct Replacement Part

Look at threshold profile and determine which replacement vinyl is required.

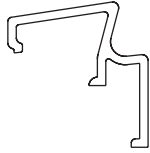

Replacement Vinyl (Woodgrain)
3/0 - RPSLIV397W
6/0 - RPSLIV697W

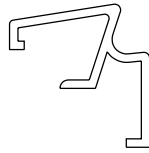

Replacement Vinyl (1992)
3/0 - RPSLIV392
6/0 - RPSLIV692

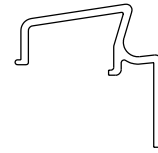

Replacement Vinyl (1993)
3/0 - RPSLIV393
6/0 - RPSLIV693

Install Vinyl Threshold

NOTE: It may be necessary to trim new threshold so it fits properly.

Hook vinyl nose into aluminum groove and rotate down around wood substrate.

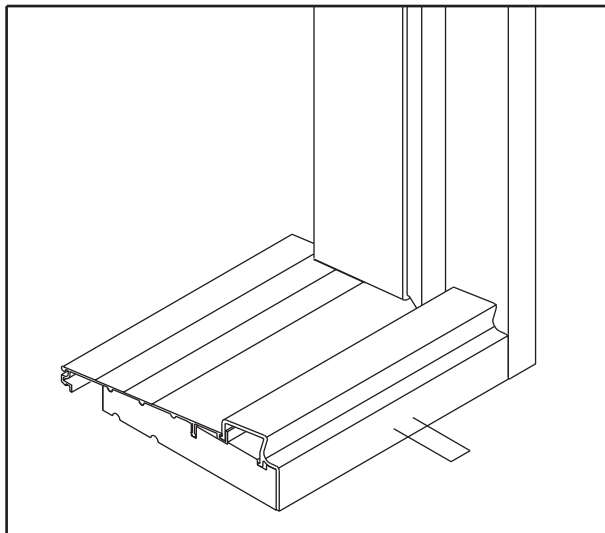
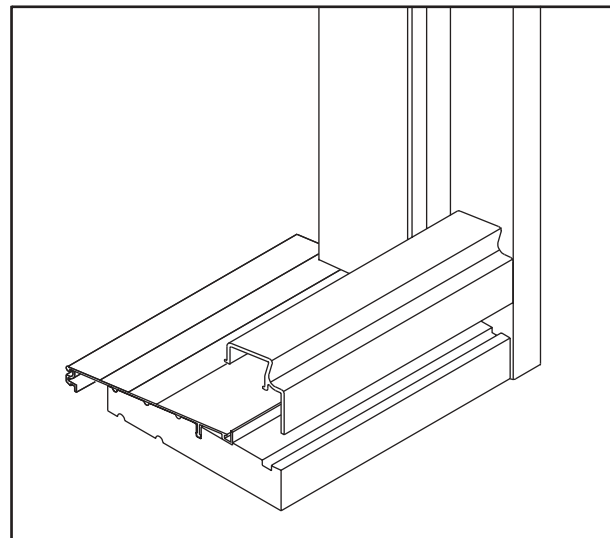

Fasten Threshold

With threshold in place, fasten back face down with staples.

**Repair
and
Replacement**

Self-Adjusting Sill Vinyl Threshold Replacement

Apply Corner Seal Pads

Place a bead of sealant at corners where threshold meets jambs.

Remove paper backing from pad.

Position pad tightly to threshold and flush with inside edge of threshold, tucking behind weather-strip.

Apply one pad at each side.

Staple pads with 5/16" galvanized staples.

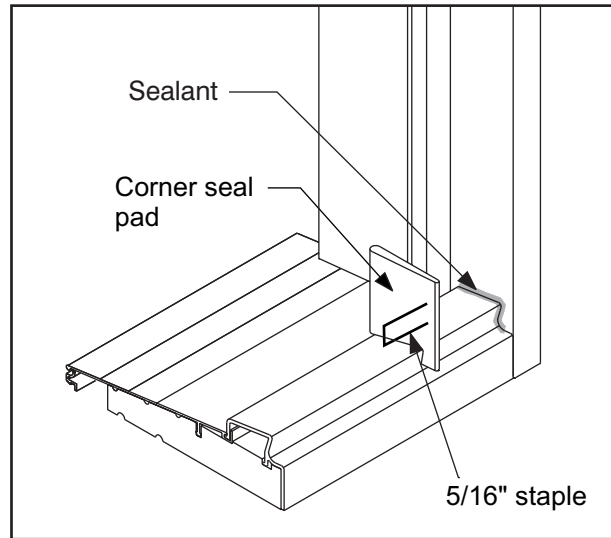

Remove Doorlite from Door or Sidelite

Remove plugs and screws from doorlite to separate lite frames.

Save plugs and screws for re-use.

Remove doorlite from door or sidelite.

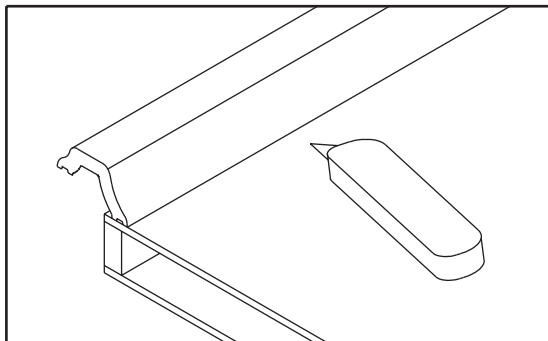
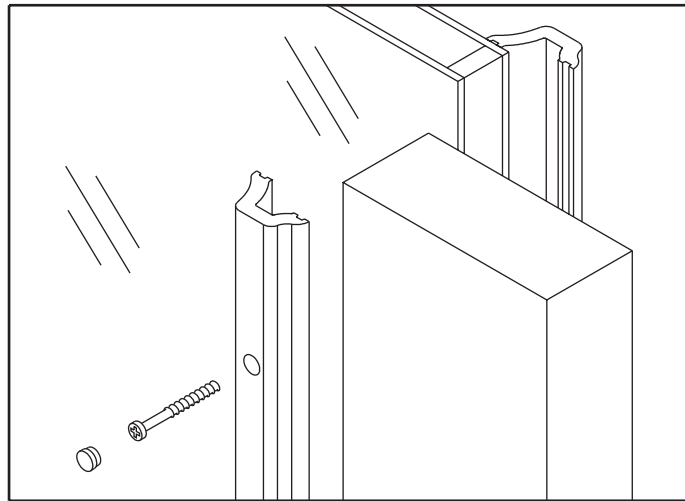

Remove Glass from Doorlite Frame

Use a heat gun or warm air from a hair dryer to soften glazing compound.

Remove glass by cutting through glazing sealant with utility knife.

Scrape off glazing sealant as much as possible from glass and frame. Remove the remaining residue *from glass only* with mineral spirits and glass cleaner.

Replace Glass and/or Frame

NOTE: Be sure surfaces are clean and dry before applying sealant.

Leaving the release backing film, on apply foam glazing tape (Part # RPGZGS) directly to the glass edges, taking care to make tight butt joints at corners. **Do not overlap. Do not Stretch.** When the tape is paced all around, peel off and discard the release backing.

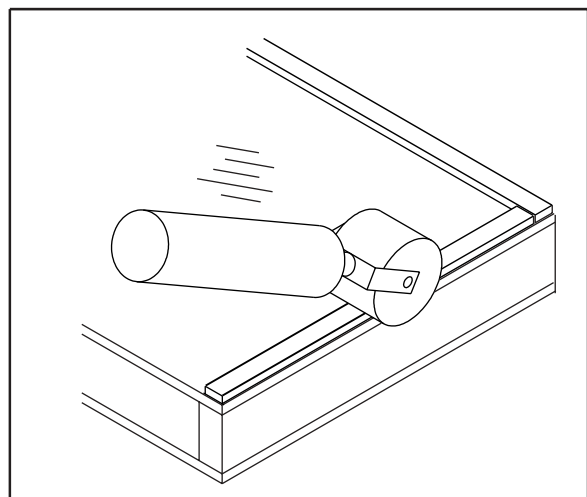
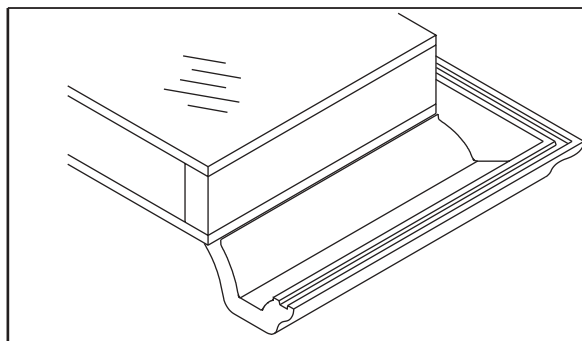

Align and insert glass onto exterior frame, pressing in place to ensure a good bond.

**Repair
and
Replacement**

Doorlite Glass or Frame Replacement

Apply Glazing Tape (if damaged)

Replace existing foam glazing tape if damaged. (Part # RPGLZTP)

DO NOT stretch.

Overlap at corners.

Press on lightly with fingers. Then with a roller tool, fully bond gasket using firm pressure.

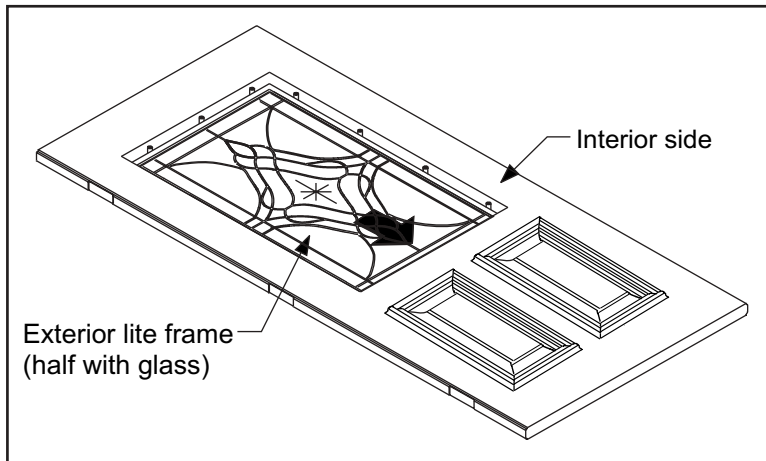
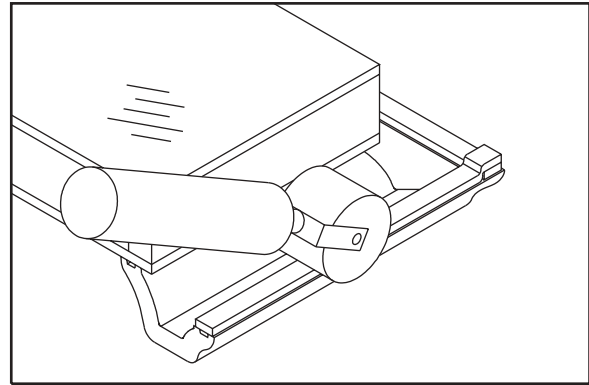

Position Lite into Opening

Place lite against bottom edge of cutout to prevent shifting.

Center lite in cutout side-to-side.

Insert Interior Frame and Drive Screws with #2 Phillips Bit

Ensure correct alignment of screw bosses.

Ensure frame edges are well-seated.

Drive screws.

Press-fit screw plugs into frame holes.

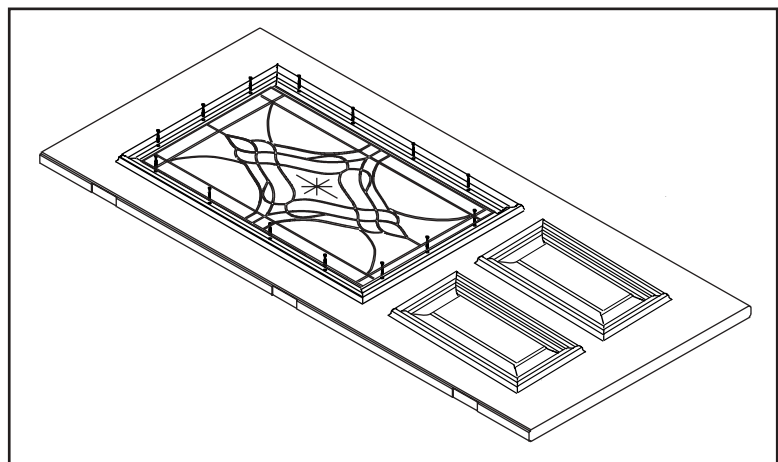

**Repair
and
Replacement**

Make Storm Door Adapter Strips

4-9/16" Jamb Adapter

Use standard mull casings (Part No. MSMLCAS). Cut to length as shown, and bevel one end to make base and face adapter strips.

One set (2 pieces - face and base adapter) is used at each mullion.

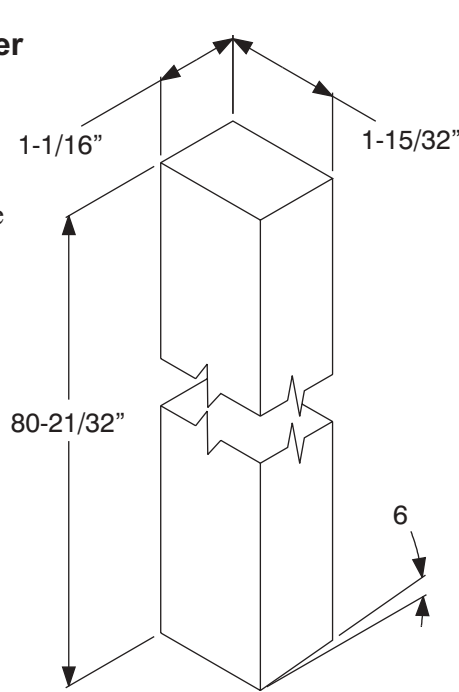

Face Adapter Strip

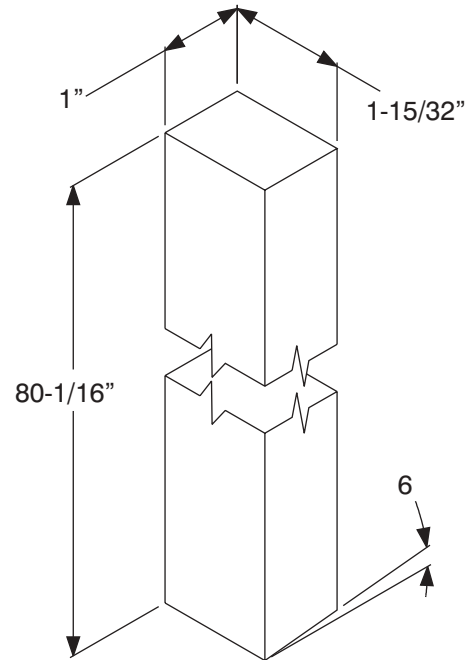

Base Adapter Strip

6-9/16" Jamb Adapter

Purchase or fabricate a base adaptor strip as shown (Part number MSSDADP).

Use one standard mull casing (Part No. MSMLCAS). Cut to length as shown, and bevel one end to make a face adapter strip.

One set (2 pieces - face and base adapter) is used at each mullion.

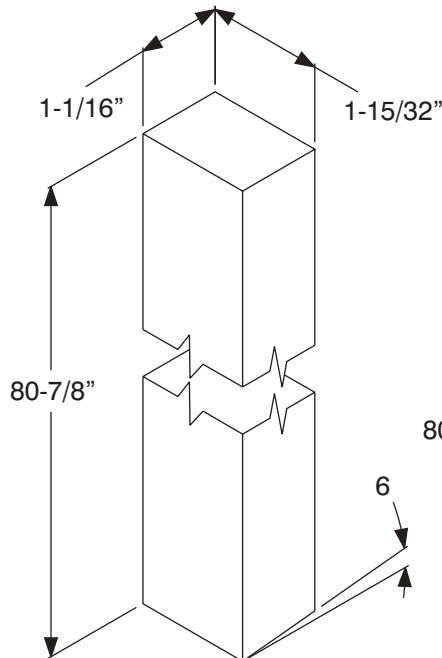

Face Adapter Strip

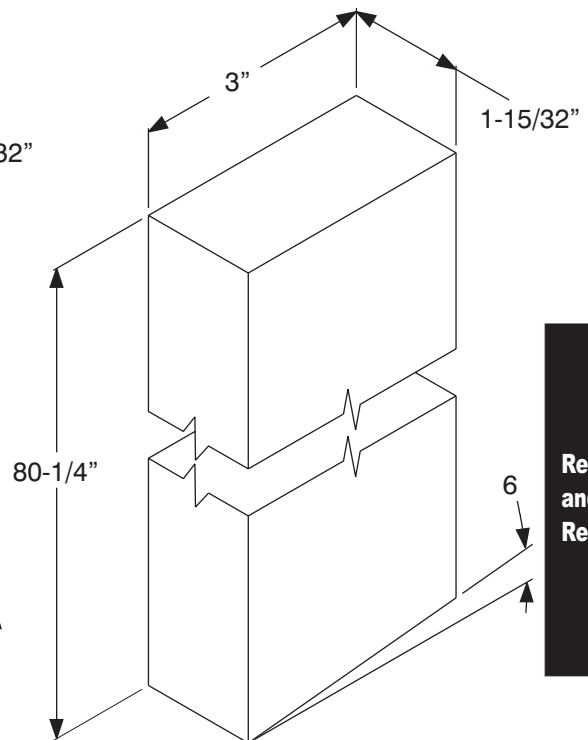

Base Adapter Strip

Repair and Replacement

Storm Door Strip Application (Continuous Sill)

Apply Storm Door Adapter

First fasten base adapter strips using #10 x 2" screws for 4-9/16" jambs or #10 x 4" screws for 6-9/16" jambs as shown.

Apply face adapter strips directly over base adapters using 2-1/2" staples.

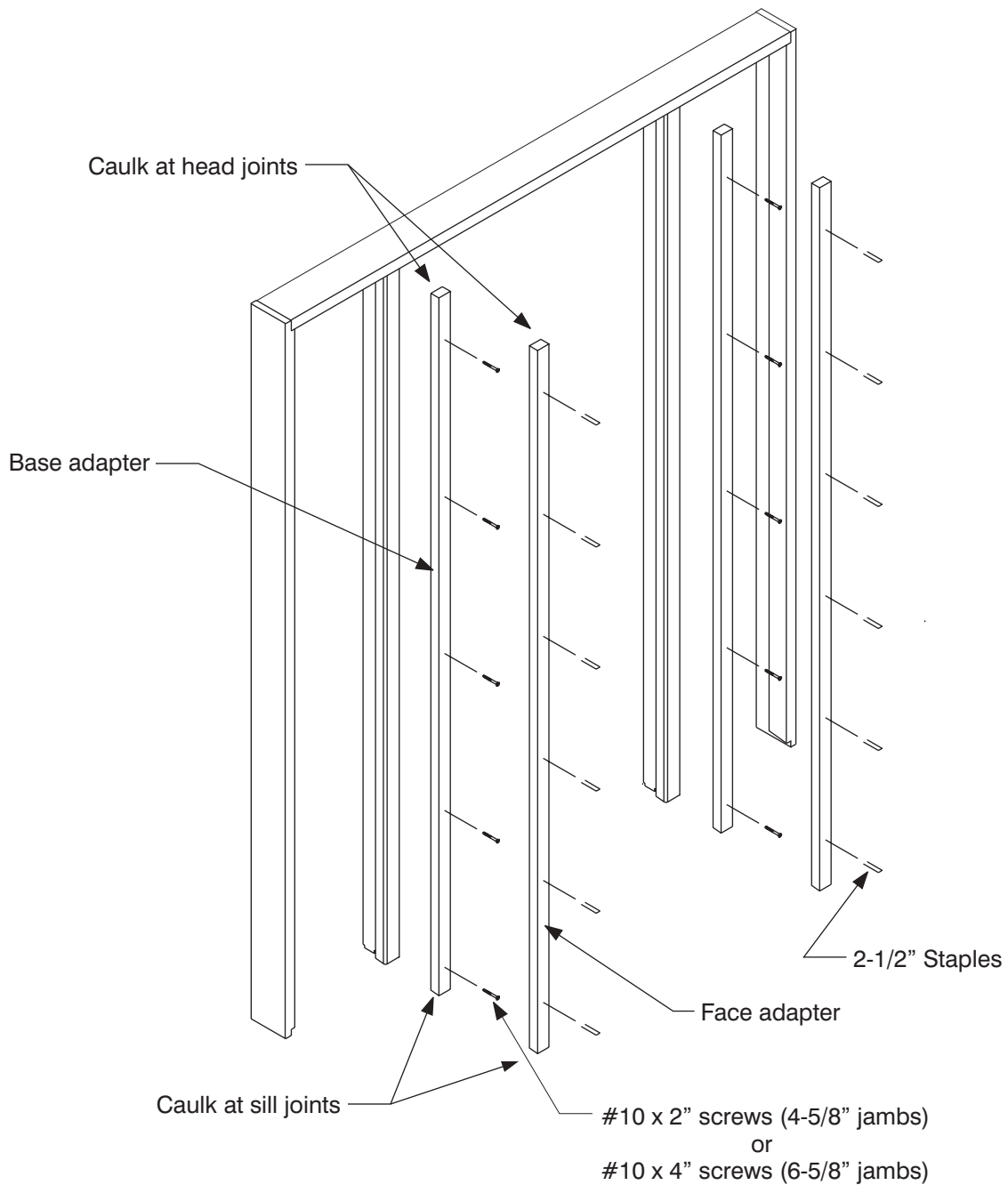

Sill removed for clarity.

Installation Instructions

- Astragal, Aluminum p.1.28
- Astragal, Multi-point Shootbolt p.1.31
- Astragal, Oak p.1.34
- Astragal, Outswing Security Cover p.1.38
- Dentil Shelf p.1.86
- Expandable Steel Frame p.1.65
- Grille p.1.82
- Jamb-Jack p.1.53
- Lite Divider p.1.85
- Pre-hung Arch/Radius Unit p.1.11
- Pre-hung High Wind Velocity p.1.13
- Pre-hung Unit p.1.3
- Sill p.1.79
- Split-Jamb Fire-Frame Site p.1.61
- Spring Hinge p.1.88
- Storm Door Strip Application p.5.29
- Transom p.1.39
- Transom Elliptical Casing p.1.51

Finishing Instructions p.2.3

- Aluminum Astragal Painting p.2.13
- Classic-Craft Painting p.2.11, 2.7
- Classic-Craft Refinishing p.3.5
- Classic-Craft Staining p.2.3
- Classic-Craft Stripping p.3.5
- Corner Tag p.1.23
- Doorlite Frame Finishing p.2.15-18
- Fiber-Classic Painting p.2.11, 2.7
- Fiber-Classic Refinishing p.3.5
- Fiber-Classic Staining p.2.3
- Fiber-Classic Stripping p.3.5
- Pre-hung Unit p.10, 1.22
- Smooth-Star Painting p.2.12
- Steel Painting p.2.12

Maintenance

- Clear & Stains p.3.3
- Corner Seal Pads p.3.4
- Door Bottom p.3.3
- Oak Riser for Adjustable Sills p.3.3
- Paint p.3.3
- Sealing/Resealing Areas p.3.4
- Sill Gaskets p.3.3
- Vinyl Threshold p.3.3
- Weatherstrip p.3.3

Painting

- Aluminum Astragal p.2.13
- Classic-Craft p.2.11, 2.7
- Fiber-Classic p.2.11, 2.7
- Smooth-Star p.2.12
- Steel p.2.12

Prehanging Instructions

- Split-Jamb Fire-Frame p.1.57

Refinishing

- Classic-Craft p.3.5
- Fiber-Classic p.3.5

Repair

- Classic-Craft Scratches p.5.5
- Dents, Steel Doors p.5.4
- Fiber-Classic Scratches p.5.5
- Stile Chips p.5.3

Replacement

- Doorlite p.5.27
- Mull p.5.12
- Sidelite p.5.6
- Threshold, Adjustable Sill Oak p.5.21
- Threshold, Self-Adjusting Sill Vinyl p.5.24
- Weatherstrip p.5.20

Staining

- Classic-Craft p.2.3
- Fiber-Classic p.2.3

Stripping

- Classic-Craft p.3.5
- Classic-Craft p.3.5

Troubleshooting

- Air Leak p.4.3
- Door not opening or closing properly p.4.9
- Door Panel Loose p.4.11
- Hinge, Spring Loaded Tension p.4.10
- Light Leak p.4.3
- Water Leak p.4.4-9

